

TYPICAL SECTION

NOTES

- POSTS: Gate posts to be 88.9 x 4 CHS galvanised steel tube, to AS 1163 and AS 4792. Corner, end and every eighth post to be 60.3 x 3.6 CHS galvanised steel tube to AS 1163 and AS 4792. Intermediate posts and goose necked stays to be 42.4 x 3.2 CHS galvanised steel tube to AS 1163 and AS 4792. Galvanised steel end caps to be provided to all posts, Galvanised to AS 4680. All posts to be vertical.
- Corner posts to be adopted where the change in angle in horizontal alignment exceeds 20 degrees.
- Stays to be provided at end posts, gate posts, corner posts and every eighth post.
- Standard couplings (down-ee fittings) may be used as an alternative to welds. For all connections except goose necked stays which shall be welded to posts.
- All welds to be 5 thick continuous fillet welds to AS 1554. with cold galvanising treatment to completed welds.
- Cables to be formed from two 3.15mm diameter wires twisted together and installed in accordance with AS 1725.
- All posts, stays and cables are to be galvanised in accordance with AS 4534, AS 4680 and AS 4792.
- All concrete N25 in accordance with AS 1379 and AS 3600.
- Chain wire to be fixed using 1.6 wire ties as follows :
Intermediate posts at 3 locations
End posts at 3 locations
Horizontal cable at 375 centres to top cable
Horizontal cable at 600 centres to middle cable
Horizontal cable at 450 centres to bottom cable.
- Barbed wire to AS 2423.
- All dimensions in millimetres.

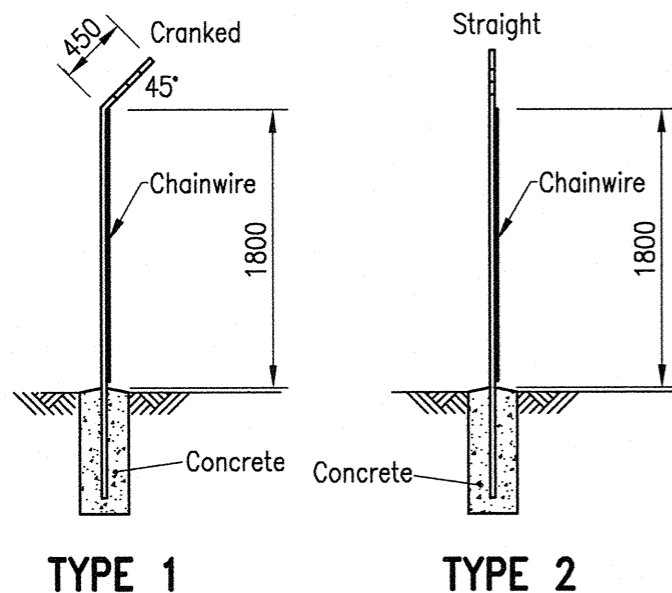

REVISIONS					
AMENDMENT	INITIALS	DATE	AMENDMENT	INITIALS	DATE
F				L	
E				K	
D				J	
C				I	
B				H	
A				G	

Notes 1 and 7 Aust. Stds. Updated
ORIGINAL ISSUE

IPSWICH CITY COUNCIL
 45 Roderick St
 P.O. Box 191
 Ipswich QLD 4305
 Australia

Tel (07) 3810 7894
 Tel (07) 3810 7927
 Fax (07) 3810 7950

APPROVED

 CHIEF OPERATING OFFICER (ES)
 DATE 14.9.10

STANDARD DRAWING

CHAIN WIRE SECURITY FENCING

ROADWORKS

SR.34

REV: B DRAWER: 100