

**BARRIER KERB/KERB AND CHANNEL**

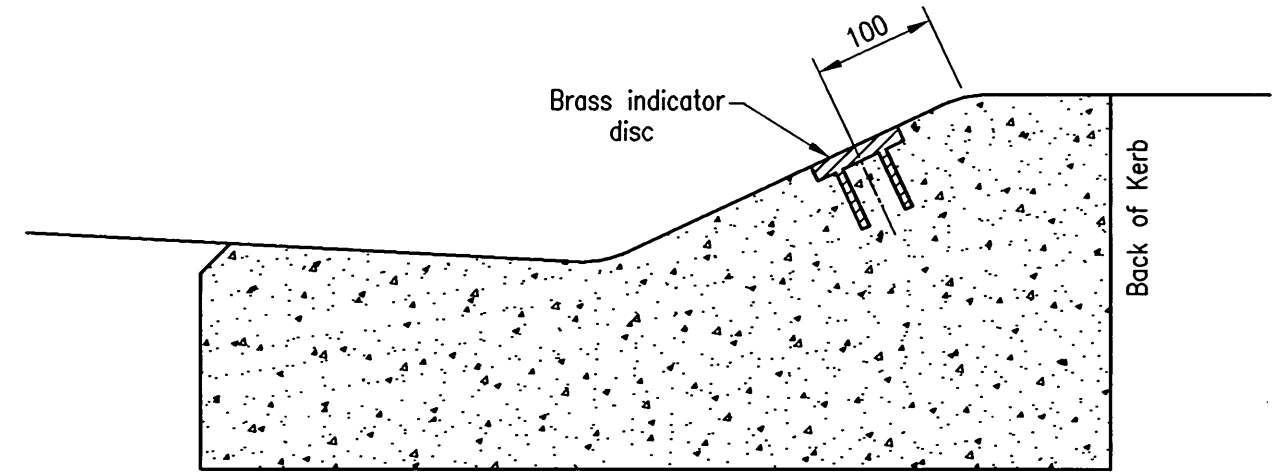

**MOUNTABLE KERB AND CHANNEL**

**POSITION ON KERB**

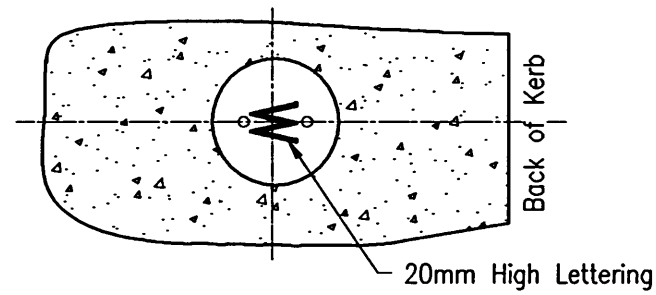

**PLAN**

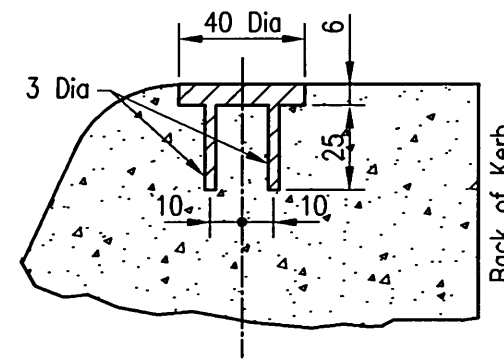

**SECTION**

**BRASS INDICATOR DISC DETAIL**

**NOTES**

1. Marker details may be varied if approved.
2. Lettering for discs to be representative as follows:  
 SD - Subsurface Drainage  
 W - Water Supply  
 G - Gas  
 T - Telecommunications  
 E - Electricity
3. All dimensions are in millimetres.

REVISIONS					
AMENDMENT	INITIALS	DATE	AMENDMENT	INITIALS	DATE
F				L	
E				K	
D				J	
C				I	
B				H	
A				G	

**IPSWICH CITY COUNCIL**

50 SOUTH STREET  
IPSWICH 4305  
P.O. BOX 191



Phone (07) 3810 7894  
(07) 3810 7927  
Fax (07) 3810 7950

APPROVED

*AA*  
WORKS MANAGER

DATE 3/6/02

**STANDARD DRAWING**

**STANDARD BRASS INDICATOR DISCS  
FOR SERVICE CROSSINGS**

ROADWORKS

**SR.24**

REV: A DRAWER: 100