

*** ALTERNATE KERB RAMP FLARE DETAIL**

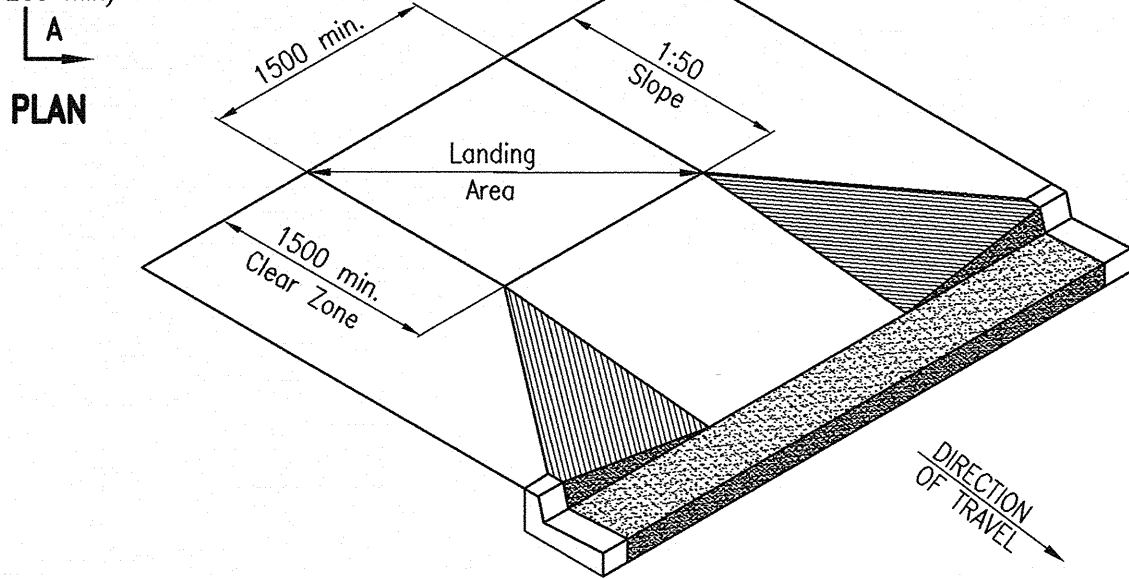

ISOMETRIC VIEW

* Alternative flare detail shall only be used where pedestrians would not be expected to cross the sides of kerb ramps. (eg.) median islands or where landscaping, handrail (min. height 900mm) or a fixed obstruction ($\phi > 300\text{mm}$) directly adjacent kerb ramp, blocks such movement.

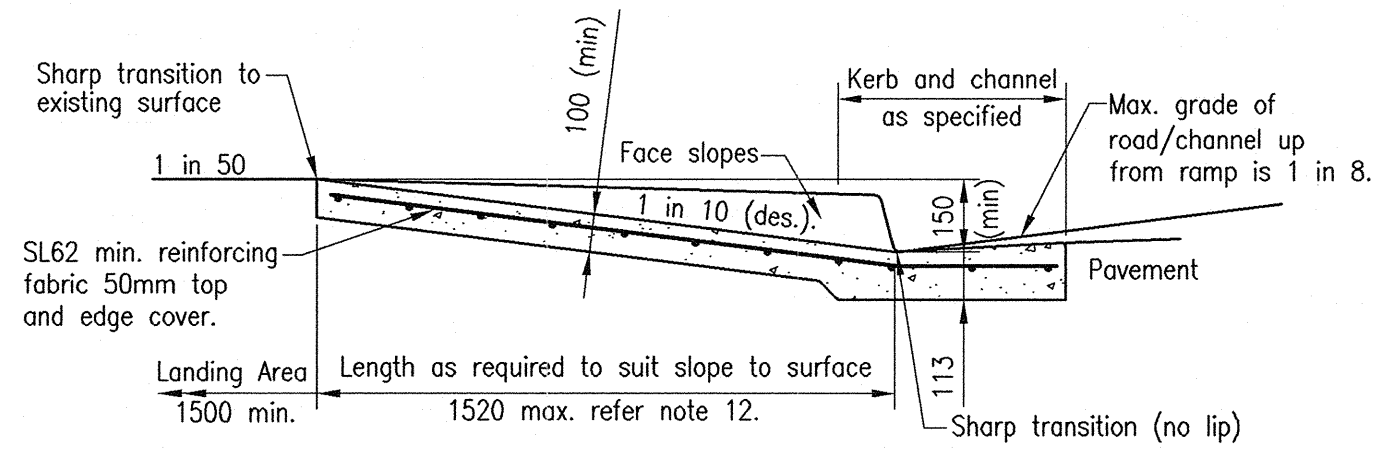

SECTION A - A

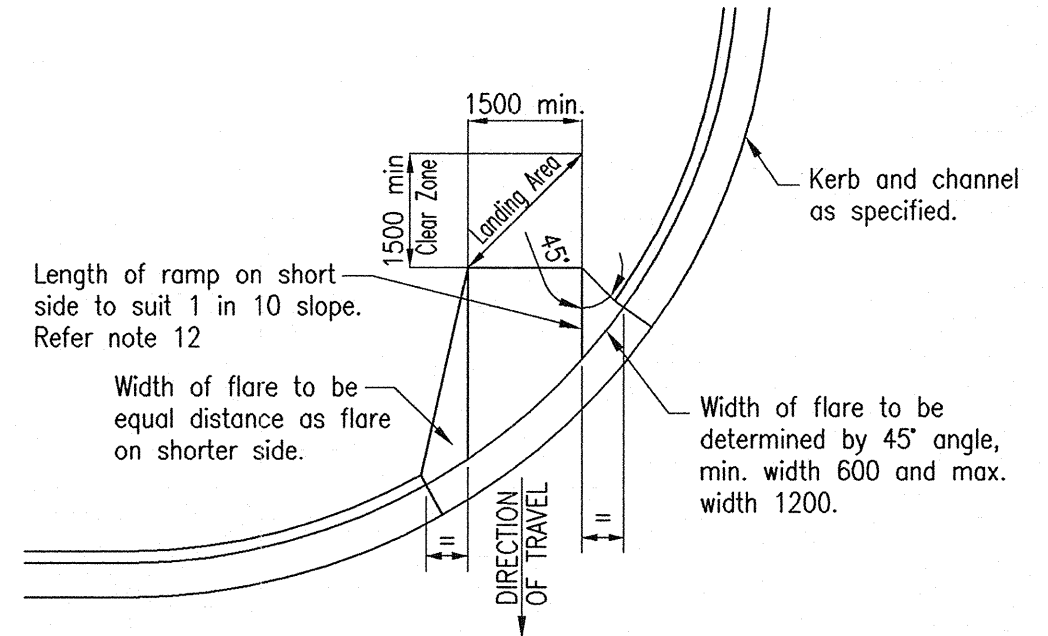

PLAN TREATMENT AT TURNOUTS

NOTES

1. For kerb ramp locations, refer project drawings.
2. Concrete N25 in accordance with AS 1379 and AS 3600
3. Kerb ramp to be cast monolithically (without construction joints).
4. Kerb ramp shall conform with AS 1428.1 and Austroads Part13.
5. Kerb ramp shall be aligned in direction of travel.
6. Tactile ground surface indicators shall only be required at signalised, and other major crossings where directed by Council's Engineer.
7. Tactile ground surface indicators shall be installed in accordance with Queensland Government Department of Main Road Standard Drawings KRG1 & KRG2.
8. All slope transitions are to be sharp transitions.
9. Strip footpaths should desirably be (re)located to avoid encroachment of the kerb ramp on to the strip footpath. If encroachment cannot be avoided, a min. strip footpath width of 1000mm shall be maintained behind kerb ramp.
10. Use same slope constraints and dimensions for mountable kerb and channel.
11. Existing kerb and channel to be saw cut to suit kerb ramp extents.
12. Kerb ramp slope may be increased to 1 in 8 max. and ramp length reduced to 1200 min. in constrained locations with approval from Council's Engineer.
13. All dimensions in millimetres.

REVISIONS					
AMENDMENT	INITIALS	DATE	AMENDMENT	INITIALS	DATE
F Footpath crossfall changed to 1 in 50				L	
E Landing Area Clear Zone Added				K	
D Un-Obstructed distance from top of ramp increased to 1500				J	
C Tactile indicator information amended.				I	
B Reinforcement added and Tactile Indicators amended.				H	
A ORIGINAL ISSUE				G	

IPSWICH CITY COUNCIL
 45 Roderick St
 P.O. Box 191
 Ipswich QLD 4305
 Australia

Tel (07) 3810 7894
 Tel (07) 3810 7927
 Fax (07) 3810 7950

APPROVED

 CHIEF OPERATING OFFICER (WPR)
 DATE 29-7-13

STANDARD DRAWING
 STANDARD KERB RAMP

ROADWORKS
SR.18
 REV: F DRAWER: 100