

SECTION: TYPICAL SECTION
SCALE: 1:40

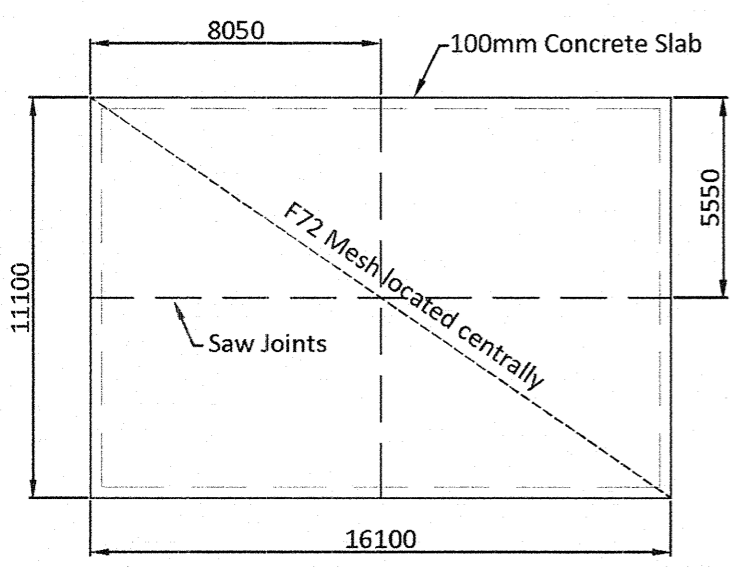

PLAN: SET OUT
SCALE: 1:200

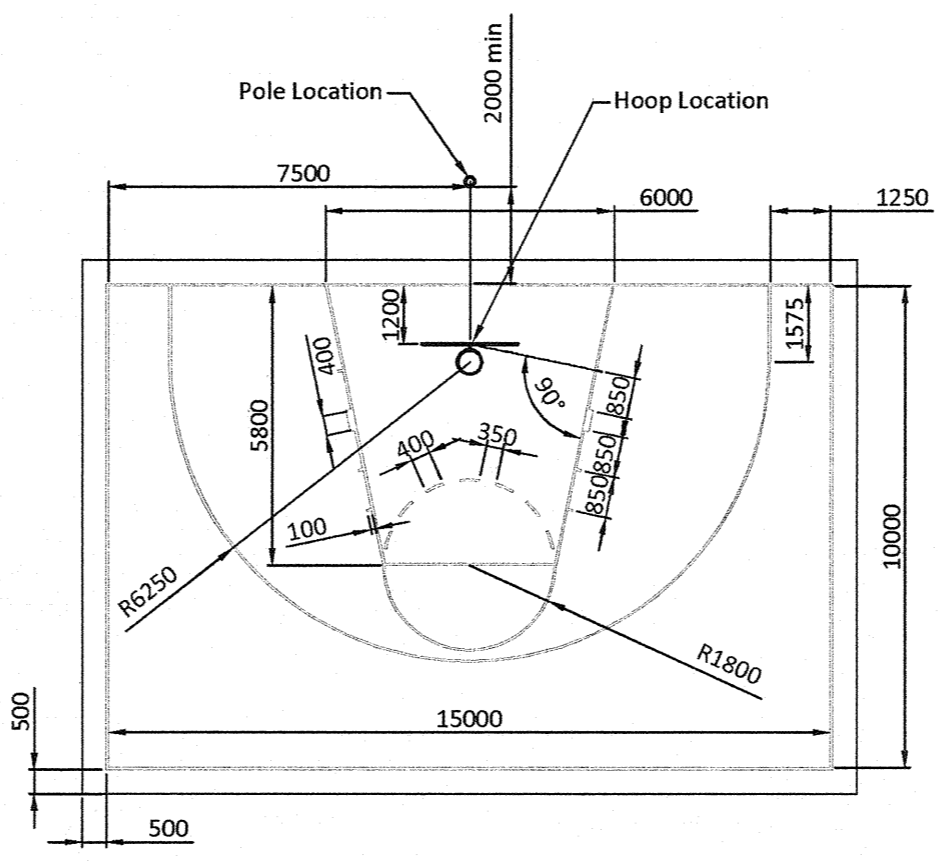

PLAN: LINE MARKING
SCALE: 1:150

NOTES:

1. Location to be marked out or approved by an Ipswich City Council representative.
2. Any batters to slab side must be max. 1:6
3. Subgrade to be proof rolled. Weak areas to be excavated and refilled.
4. Fill areas to be min 250mm compacted CO CBR60 roadbase at 90% compaction.
5. All construction and materials to AS3600-2009
6. Damp proof membrane 0.2mm polyethylene film to be placed under concrete slab and beams with 200mm laps taped at joints.
7. Reinforcing SL72 square mesh grade 500 to comply with AS4671-2001.
8. Welding of reinforcement is not permitted.
9. Saw cut into equal sections 25mm deep within 24hrs of concrete pour.
10. Line marking to be 50mm wide.

HOOP SPECIFICATIONS:

1. Supply and install hoop, backboard and post in accordance with Australian Basketball Federation Guidelines.
2. Engineer's certification required for hoop, post, backboard and footing.
3. Install to manufacturer's written instructions

REVISIONS					
AMENDMENT	INITIALS	DATE	AMENDMENT	INITIALS	DATE
F				L	
E				K	
D				J	
C				I	
B	Notes Altered			H	
A	ORIGINAL ISSUE			G	

IPSWICH CITY COUNCIL
 45 Roderick St
 P.O. Box 191
 Ipswich QLD 4305
 Australia

Tel (07) 3810 7894
 Tel (07) 3810 7927
 Fax (07) 3810 7950

APPROVED

 CHIEF OPERATING OFFICER (WPR)
 DATE 29-7-13

STANDARD DRAWING
 SPORTS AMENITY
 BASKETBALL HALF COURT

PARKS
 SP.69
 REV: B DRAWER: 100