

**FRONT ELEVATION**  
Scale: 1:25

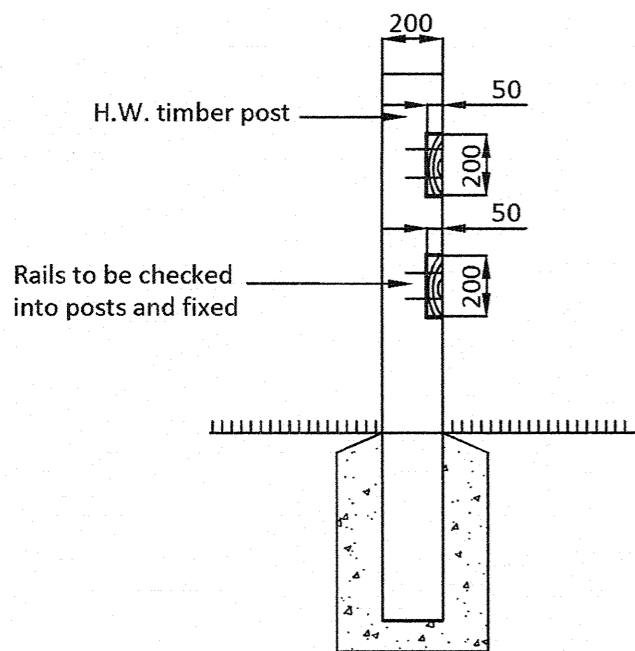

**SIDE POST ELEVATION**  
Scale: 1:25

- NOTES:**
1. All timber to be durability class 1 H.W. timber F14, cut free from sapwood.
  2. Concrete footings are to be no fines concrete, 10mm max aggregate size and shall be ready mixed or hand mixed in accordance with AS1379-2007.
  3. Ensure smooth surface, free from splinters to all external timber faces, edges and chamfers.
  4. Apply 5mm chamfer to all edges.
  5. Where a coloured finish is required, paint timber with 1 no. coat of oil based primer and 2 no. coats of approved acrylic exterior paint. Colour as specified by ICC.
  6. Where a natural finish is required, paint timber with 1 no. coat of approved clear water repellent following fabrication. Following installation, paint assembly with 1 no. coat of the same.

REVISIONS					
AMENDMENT	INITIALS	DATE	AMENDMENT	INITIALS	DATE
F				L	
E				K	
D				J	
C				I	
B				H	
A				G	

ORIGINAL ISSUE

**IPSWICH CITY COUNCIL**  
 45 Roderick St  
 P.O. Box 191  
 Ipswich QLD 4305  
 Australia

Tel (07) 3810 7894  
 Tel (07) 3810 7927  
 Fax (07) 3810 7950

APPROVED  
  
 CHIEF OPERATING OFFICER (WPR)  
 DATE: 29-7-13

**STANDARD DRAWING**  
**FENCE: NATURAL AREAS/BUSHLAND TWO RAIL TIMBER**

PARKS  
**SP.100**  
 REV: A DRAWER: 100